

## MetalWorks Vector

### 1. GENERAL

#### 1.1 Product Description

METALWORKS Vector is a downward accessible galvanized steel ceiling panel available in standard 600 x 600 size (1200x300/400/600mm also available). It is designed to install on a conventional 24mm wide Armstrong PeakForm Prelude XL T-Bar suspension system. All full panels can be removed and reinstalled without movement up into the plenum area.

Installed Vector panels are supported by two sides. These edges have specially designed kerf details with springs that allow the panel to move in one direction, disengage from the suspension system flange and then be lowered out of the ceiling. The other two sides are fitted with rabbeted edges, which work to center the panel within the suspension system opening.

#### 1.2 Surface Finish

METALWORKS Vector panels are powder-coated and available perforated or unperforated. The perforated finishes have a Black acoustical fleece factory-applied to the back side of the panel. The surface of these panels is washable, scrubbable, soil resistant, and non-directional.

#### 1.3 Storage and Handling

The ceiling panels shall be stored in a dry interior location and shall remain in cartons prior to installation to avoid damage. The cartons shall be stored in a vertical position. Proper care should be taken when handling to avoid damage or soiling.

**NOTE:** MetalWorks Vector panels are packaged with the face of the panel toward the outside of the carton. Exercise care in moving and opening cartons to prevent damage to the panel face.

#### 1.4 Site Conditions

Building areas to receive ceilings shall be free of construction dust and debris.

#### 1.5 Interior Applications

Armstrong METALWORKS ceilings are **INTERIOR FINISHES ONLY** and conditions during the installation should reflect this. Armstrong recommends during installation that relative humidity should not exceed 99%, within a temperature range of 0 to 49 degrees Celsius and with the absence of

any "standing water". Conditions following completion should be maintained as such.

Because of the risk of soiling, the installation of ceiling tiles should only take place after the completion of any work generating large amounts of dust. The wearing of clean gloves is recommended for installation work. The ceiling installer is responsible for the satisfactory installation of the ceiling and adherence to industry best practice and in accordance with AS/NZS2785:2020

Ceiling tiles should only be stored in a dust-free and dry area. It is important to ensure that the tiles are not subjected to any mechanical influences, such as damage caused by the underlying surface. Ceiling tiles delivered on pallets should be stored in their original packaging until they are installed. Where this is not possible, care should be taken to ensure that cartons are stored with the designated side facing upwards. The installation company is responsible for the careful storage of tiles.

The integrity of the entire suspended ceiling depends on the hangers – commonly 5mm gal rod is used, with some contractors using 2.5mm wire and M6 Threaded Rod (Both types meet Australian / New Zealand standard 2785-2020) which are used to support the Carrier Channel. Bracing is to be applied where required to ensure the Suspension System remains square.

**\*Note: Specially designed MetalWorks Ceilings for EXTERIOR applications are available upon request. Contact your Armstrong Ceiling Solutions Representative for details and conditions.**

#### 1.6 Plenum

Installation of METALWORKS Vector panels requires 50mm of clearance above the suspension system to permit deployment of the security clips.

**NOTE:** Light fixtures and air handling systems require more space and will usually determine the minimum plenum height for the installation.

## 2. PANEL EDGES

### 2.1 General

The edges of the MetalWorks Vector panels feature unique detailing. The following section is intended to define and explain the function of the edge details.

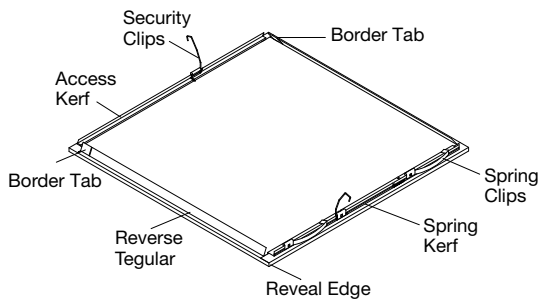

### 2.2 Spring Kerf

As the name implies, this edge is fitted with two steel spring clips that serve to hold the panel in position. This edge is the first to engage the suspension system.

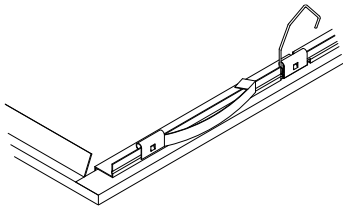

### 2.3 Access Kerf

This edge has a simple kerf detail that serves to locate the panel on the suspension system flange when the springs push in this direction. This edge is opposite the spring kerf, and is the edge that is pressed to disengage a panel for the purpose of attaining "access" to the plenum.

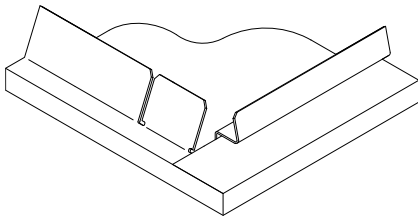

### 2.4 Reverse Tegular Edges

The two remaining panel edges are rabbetted to fit between the flanges of the suspension system. These edges center the panel in the suspension system opening and are called reverse Tegular edges.



## 3. SUSPENSION SYSTEM

### 3.1 General

The suspension system shall be standard Prelude® 24mm Exposed Tee suspension system. The suspension system, whether new or existing, shall be properly installed and leveled. Suspension system installation shall conform to AS/NZ 2785:2020.

### 3.2 Suspension System

MetalWorks Vector panels install in a 600 X 600 module. The main beams shall be spaced 1200mm O.C. The 1200mm cross tees shall intersect the main beams at 90° every 600mm. The 600mm cross tees shall be installed at the midpoints of the 1200mm tees.

### 3.3 Panel Face Offset

The face of the MetalWorks Vector panel extends 10mm below the face of the suspension system. The height of components that interface with the ceiling panels, such as sprinkler heads and light fixture trim rings, will have to be adjusted to accommodate this 10mm offset.

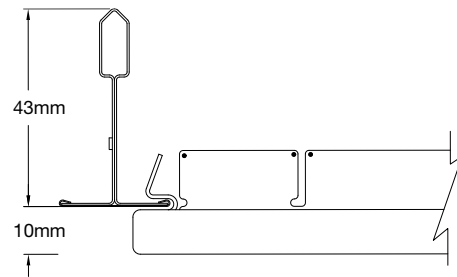

### 3.4 Panel Penetrations

Holes cut for sprinkler heads and other services that penetrate the ceiling panel must be cut slightly oval shaped to allow the panel to move 6mm in the direction of the spring kerf edge. Additionally, trim rings for these devices must be wide enough to accommodate this 6mm movement.

### 3.5 Cutting Options

Cutting procedures will be similar regardless of panel material or edge configuration. Two different types of equipment are recommended for cutting these metal panels. Each has its own set of advantages and limitations and will be presented in order of preference based on speed.

**CAUTION:** Cut edges of metal parts can be extremely sharp! Handle metal carefully to avoid injury. Always wear safety glasses and gloves when working with metal.

#### 3.5.1 Electric Shears or Nibblers

These electric shears resemble a drill motor attached to a pair of scissors blades. There are actually three blades; one movable centered between two stationary. When used, the tool removes a strip of material about 8mm wide.

They produce a clean cut, and is quicker than using aviation snips.

**Procedure:** Mark the cut line on the face of the panel. Use aviation snips to remove a section of the edge material on the waste side of the cut line.

This step is required to provide access to the face for the shears. Cut the panels face up.

**NOTE:** To prevent scratching the face of the panel, observe the direction that the 8mm band of waste material takes as it coils up in front of the cut. Position successive panels so that this coil moves across the scrap portion of the panel.

#### 3.5.2 Aviation Snips

Both left cut and right cut aviation snips will be required for notching operations and for cutting holes for penetrations through the panel face.

**Procedure:** Notching Snips are used as needed to cut through the edge detailing on panels to provide clearance for shears or to ease corners.

Application will vary depending on edge detail.

### 3.5.3 Penetrations Cutouts

Procedure: Penetrations are created by first drilling or punching a hole near the center and then cutting in a spiral pattern to the finished size and shape.

Exercise caution during this procedure as the hand will be in close proximity to the cut edge of the panel.

## 4. PANEL INSTALLATION & REMOVAL

### 4.1 General

MetalWorks Vector ceiling panels are easily installed and removed from below the suspension system without the aid of tools or special equipment, allowing easy downward access to the plenum.

### 4.2 Installing Full-size Panels

The panels are installed in a simple three-step process.

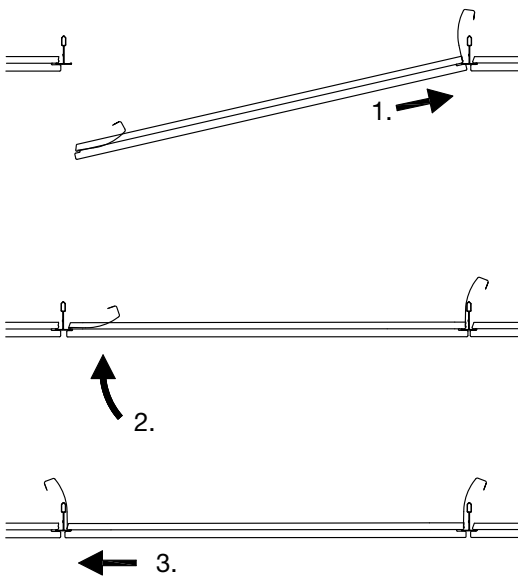
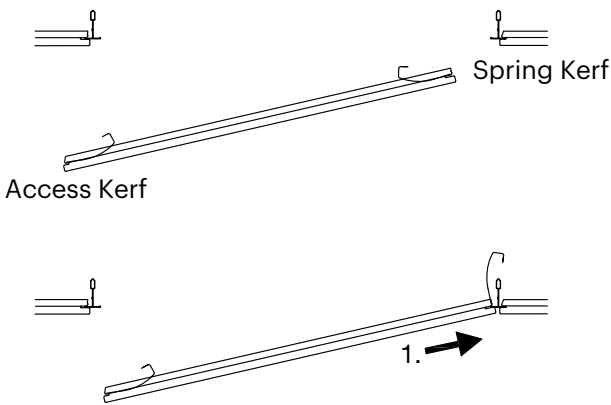

**STEP 1:** Fully insert the spring kerf onto the exposed suspension system flange.

**STEP 2:** Raise the panel into the suspension system module until horizontal.

**STEP 3:** Slide the panel in the direction of the access kerf to fully position and center the panel in the suspension system.

**NOTE:** The security clips are automatically positioned when the suspension system flanges enter the kerfs.

### 4.3 Orientation of Full Panels

Install all full-sized panels with the spring kerfs facing in the same direction to provide access consistency.

### 4.4 Panel Removal

Removal is simply the reverse of installation.

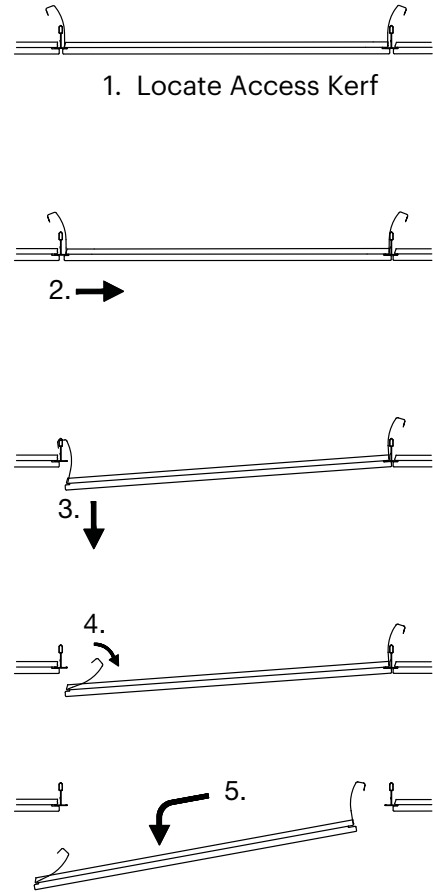

**STEP 1:** Locate the access kerf by pushing on the panel edges until the panel moves.

**STEP 2:** Push on the access kerf edge until it clears the suspension system flange.

**STEP 3:** Lower the kerfed edge of the panel and locate the security clip.

**STEP 4:** Hold the panel with one hand while pushing the security clip away from the cross tee.

**STEP 5:** Slide the panel back and down to remove it from the suspension system module.

**NOTE:** Do not allow the panels to hang by the security clips while working in the plenum.

## 5. PERIMETER DETAILS

### 5.1 General

While the actual materials used to trim out the perimeters of a MetalWorks Vector installation are varied, installations will fall into one of two categories; either the panels will all be full size or the cut edges will rest on and be concealed by some form of Perimeter Trim.

### 5.2 Cut Panel Installations

Another option is to have the suspension system raised above the trim by 10mm. This clearance will allow the face of the panel to pass over, and rest upon the support leg of the trim.

**Note:** It is always the spring kerf panel edge that is cut off of border panels.

### 5.3 Cutting and Installing the Panel

#### CAUTION

Cut edges of metal parts can be extremely sharp! Handle metal carefully to avoid injury. Always wear safety glasses and gloves when working with metal.

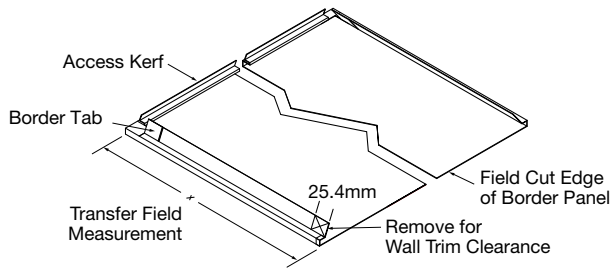

**5.3.1** Cut the panel as marked.

**5.3.2 Border Tabs** Reach over top of the suspension system and fold the border tabs down to secure the cut panels in the suspension system.

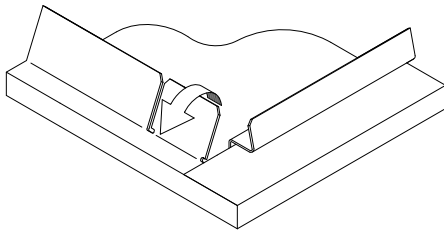

#### Backloading

Unless approved, Armstrong metal ceilings are designed to support only their own weight plus that of Soundtex acoustical scrim or other light weight insulation. All

mechanical services must be independently supported. Contact Armstrong for more information on B15 acoustical solutions and support trays for services.

## 5. MAINTENANCE

Ceiling tiles may be cleaned at any time. However, any maintenance work on suspended ceilings should only be carried out after the technical functions of the ceiling installation have been carefully checked. In cases of doubt, the relevant Armstrong sales office should be contacted.

In the case of damage to individual ceiling tiles, these can be exchanged within the systems. In such instances, especially after extended periods of use, colour variations may occur when individual tiles are replaced.

### 5.1 Armstrong – paint coatings

Armstrong ceiling tiles in general are electrostatically paint coated or finished with a polyester powdercoat.

### 5.2. Cleaning of Armstrong METALWORKS™ metal ceilings

The frequency of cleaning will depend upon the function and usage of each area and the efficiency of the air conditioning/heating system. This period can only be determined after handover and occupancy. Although the ceiling materials are provided with durable paint finish, abrasive or strong chemical detergent should not be used. A mild detergent diluted in warm water applied with a soft cloth, rinsed and finally wiped off with a chamois leather will maintain the ceiling in good condition. Oily or stubborn stains if not removed by washing can be wiped off with white spirit but care is necessary to avoid affecting the gloss level of the paint finishes.

## MORE INFORMATION

For complete technical information, detail drawings, CAD design assistance, installation information and many other technical services, call your local Armstrong Ceilings representative.

For the latest product selection and specification data, visit [armstrongceilings.com.au](http://armstrongceilings.com.au)

## Contact us

#### NSW/ACT

Armstrong Ceiling Solutions (Australia) Pty. Ltd.  
Unit 4, 1 Basalt Road, Pemulwuy NSW 2145  
Telephone (02) 9748 1588

#### VIC/TAS

Armstrong Ceiling Solutions (Australia) Pty. Ltd.  
Unit 1, 88 Henderson Road, Rowville VIC 3178  
Telephone (03) 8706 4000

#### QLD / NT

Armstrong Ceiling Solutions (Australia) Pty. Ltd.  
6 Barrinia Street, Slacks Creek QLD 4127  
Telephone (07) 3809 5565

#### SA

Total Building Systems Pty. Ltd.  
160 Grand Junction Road, Blair Athol SA 5084  
Telephone (08) 7325 7555

#### WA

Ceiling Manufacturers of Australia Pty. Ltd.  
3 Irvine Street, Bayswater WA 6053  
Telephone (08) 9271 0777

#### New Zealand

Forman Building Systems Ltd.  
27B Smales Road, East Tamaki, Auckland 2013  
Telephone 64-9-276 4000

  
CEILING SOLUTIONS