

MetalWorks Modular Beams Installation Guide



MetalWorks Modular Beams Installation Guide

1. GENERAL

DO NOT REMOVE BEAMS FROM THE CARTON UNTIL YOU HAVE READ THESE INSTRUCTIONS IN THEIR ENTIRETY.

1.1 Product Description

The Armstrong METALWORKS Modular Beams ceiling system consists of a range of extruded aluminium Beam profiles which are suspended by the Armstrong Aircraft Cable Hanging System as per details below.

The Modular Beam System is made up of a Primary Beams installed at the specified spacing, with Secondary (Cross) Beams cut to size and connected at right angles to the Primary beams to suit the specified module.

1.2 General Installation Conditions

Armstrong METALWORKS ceilings are **INTERIOR FINISHES ONLY** and conditions during the installation should reflect this. Armstrong recommends during installation that relative humidity should not exceed 99%, within a temperature range of 0 to 49 degrees Celsius and with the absence of any "standing water". Conditions following completion should be maintained as such.

Because of the risk of soiling, the installation of ceiling tiles should only take place after the completion of any work generating large amounts of dust. The wearing of clean gloves is recommended for installation work. The ceiling installer is responsible for the satisfactory installation of the ceiling and adherence to industry best practice and in accordance with AS/NZS2785:2020

Ceiling tiles should only be stored in a dust-free and dry area. It is important to ensure that the tiles are not subjected to any mechanical influences, such as damage caused by the underlying surface. Ceiling tiles delivered on pallets should be stored in their original packaging until they are installed. Where this is not possible, care should be taken to ensure that cartons are stored with the designated side facing upwards. The installation company is responsible for the careful storage of tiles.

The integrity of the entire suspended ceiling depends on the hangers (Australian / New Zealand standard 2785-2020) which are used to support the Main Beams. Bracing is to be applied where required to ensure the Suspension System remains square.

***Note: Specially designed MetalWorks Ceilings for EXTERIOR applications are available upon request. Contact your Armstrong Ceiling Solutions Representative for details and conditions.**

1.3 Fire Performance

METALWORKS Modular Beams may obstruct or skew the existing or planned fire sprinkler water distribution pattern, or possibly delay the activation of the fire sprinkler or fire detection system. Designers and installers are advised to consult a fire protection engineer.

1.4 Before You Start

All material delivered to site should be checked for damage, unopened and original packages. At this stage if you are unsure of the suitability of material for this project, ask questions, as it is very expensive to remove materials that have been installed. All materials to be kept dry and protected from the elements

1.5 Other Conditions

Unless specified and approved by Armstrong, METALWORKS Modular Beams cannot be used to support any other material.

MetalWorks Modular Beams Installation Guide

2. INSTALLATION

2.1 General

METALWORKS Modular Beams may require two people to install and align. The suspension system chosen must be fastened to the structure in accordance with building code in your area.

2.2 Plenum Space

The installation of Armstrong METALWORKS® Modular Beams requires no more space in the plenum than that which is required to hang the suspension system. Beams never need to travel into the plenum space during installation or removal.

2.3 Determine Ceiling Orientation

It is important at this stage to determine the direction the ceiling Beams to be installed. The drawings and specification supplied by the builder will show the direction, location, and spacing of the Primary Beams required for the project. Primary Beams are typically oriented perpendicular to the roof purlins or joists.

2.4 Modular Beams Suspension

Beam Layout

Primary Beams are to be installed parallel, with layout as per drawings and specification. Cross Beams connect to the Primary Beams at 90 degrees, also as per drawings and specification.

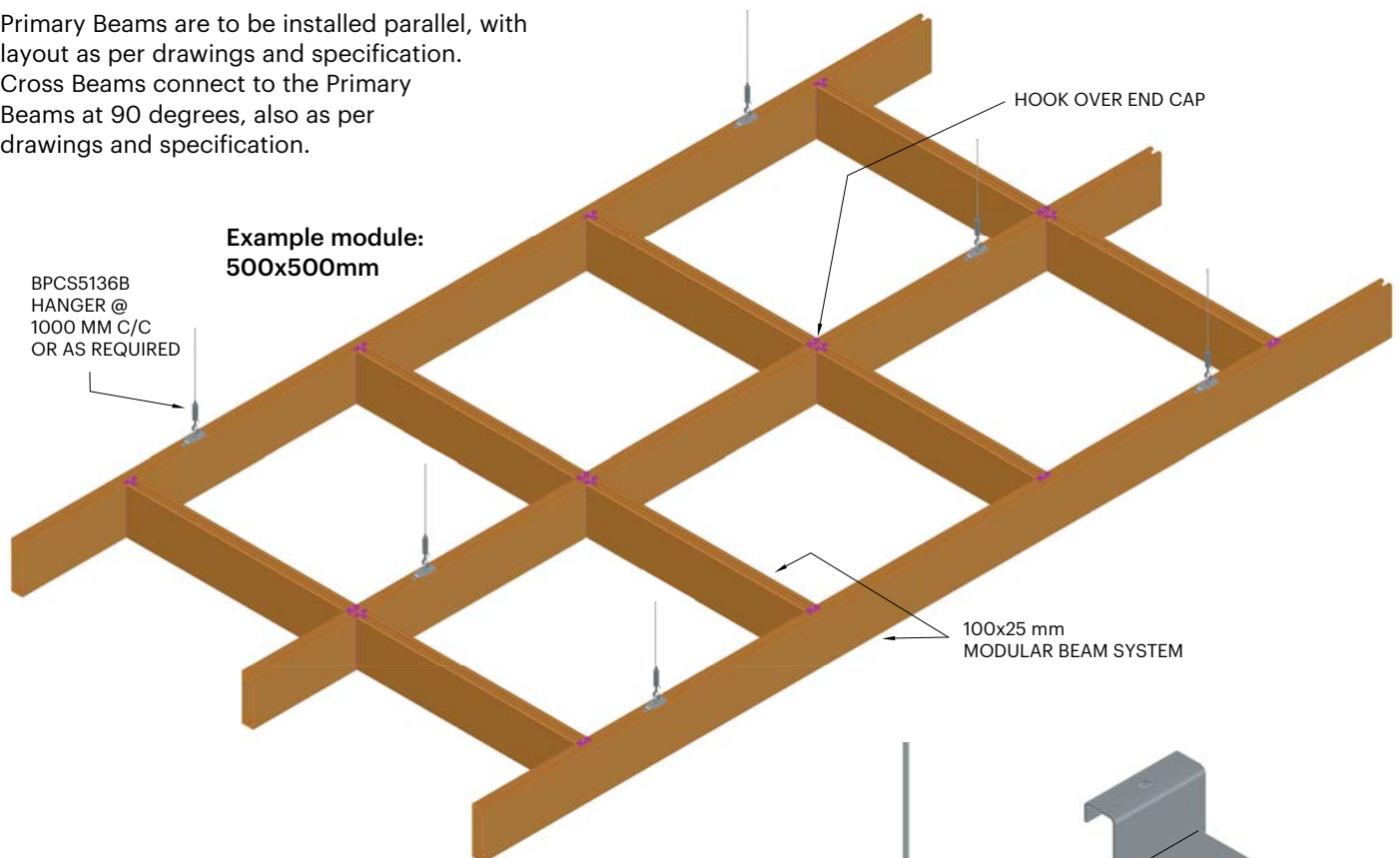

Modular Beams Suspension System Components

Item	Description
BAF1003600_*	Beam: 100x25
BAF100503600_*	Beam: 100x50
BAF100HOECM	Hook Over End Cap: 100x25
BAF10050HOECM	Hook Over End Cap: 100x50
UNI112S	Joiner
BPCS5136B	Hanger

* Refers to Beam Colour: EG WH for Satin White or BL for Black

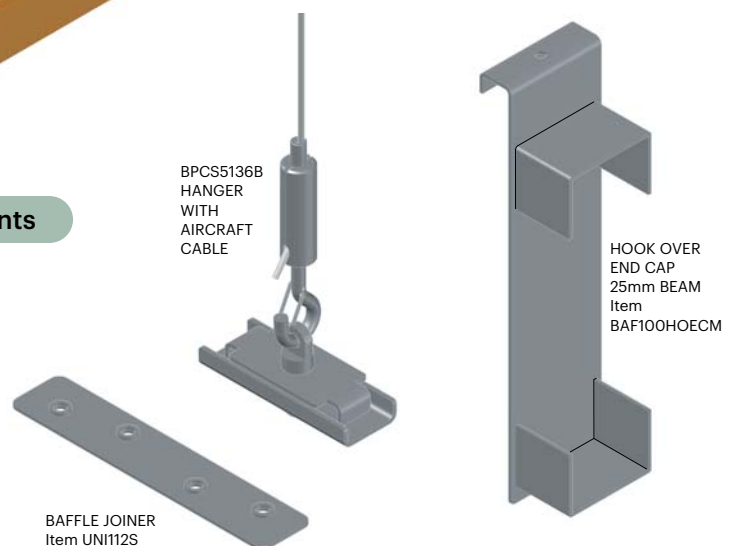

MetalWorks Modular Beams Installation Guide

2.5 Modular Beams Hanging Kit

METALWORKS Modular Beams are suspended using Aircraft Cables and “quick release” Adjusters (Hanging Kit BPCS5136B).

1. Beams are to be suspended along their length at 1000mm centres.
2. Fasten appropriate anchors to the structure. You must have a hole to loop the Aircraft Cable through on the anchor.
3. For each suspension point – Insert an aircraft cable into the top of the Gripper Cable Adjuster.
4. Insert the Gripper Hook into the bottom of the Cable Adjustor.

Assembled Detail

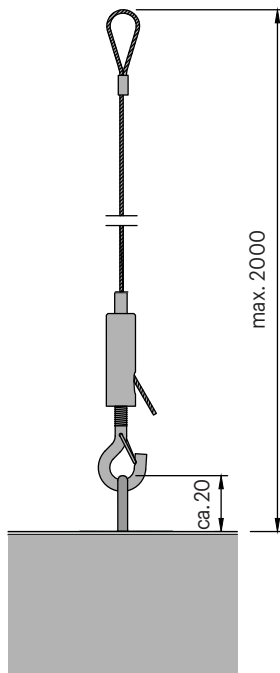

BPCS5136B – 4 items/kit

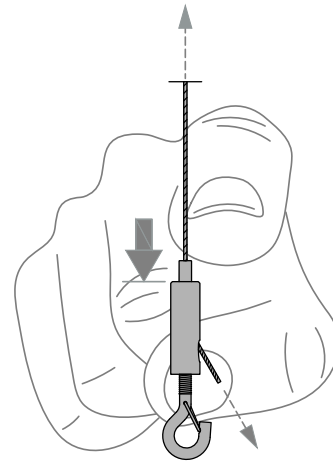
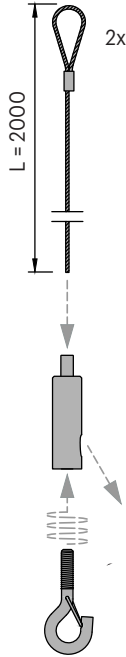

IMPORTANT SAFETY AND QUALITY NOTE: Do not allow any portion of wire or aircraft cable to drop below the top of a Beam while adjusting final height. To do so could cause injury to the installer or scratch the edge of the Beam.

After the panel height is correct, cutoff excess cable leaving about 25mm remaining out the cable adjuster.

2.6 Installation of the Modular Beam Profiles

Unless specifically ordered, Beams will be factory produced to a nominal size, typically 3,600mm. Beam extrusions may need to be trimmed to exact dimension, which can be done simply, on site, using an aluminium drop saw.

1. Locate the Beam Suspension Clamping Bracket into the top of the Beam as shown in drawing (Fig 1 & 2 – refer page 5). The Clamping Bracket consists of three elements: Bottom U shaped Plate, Top Plate and Eye Bolt.
For 25mm Beam (Fig 1) – From either end of Beam, slide in Clamping Brackets and locate into position (1000mm along length). Ensure the Hanger’s Clamping Bracket is assembled as per image in Fig 1 (page 5): The Top Plate of the Clamping Bracket must have wings positioned facing downward. Finger tighten in position by turning the top of the eye bolt.
For 50mm Beam (Fig 2) – Locate Brackets at 1000mm centres along length of Beam. Ensure the Hanger’s Clamping Bracket is assembled as per image in Fig 2 (page 5): The Top Plate of the Clamping Bracket must have “wings” positioned facing upward. Finger tighten in position by turning the top of the eye bolt.
2. Beams are then lifted into position.
3. Attach Gripper bottom end assembly to Beam Clamping Bracket.
4. Gently pull the cable through the Cable Adjuster until all the slack is removed
5. To release the cable, take all weight off the Adjuster, push the release mechanism, and simply slide the cable out as needed.
8. Level the Beam and trim the Aircraft Cable at the desired length.

MetalWorks Modular Beams Installation Guide

Fig 1. Locating the Clamping Bracket in the 25mm Beam

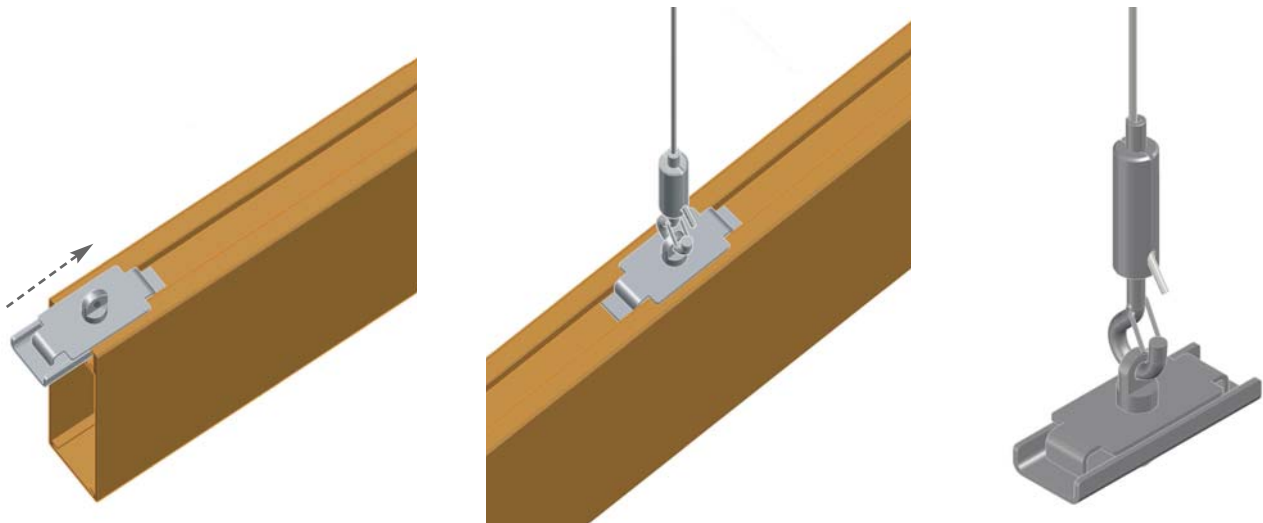

Slide Clamping Bracket from end of Beam

Position Clamping Bracket at 1000mm OC. and attached Gripper Hook

Note: For 25mm wide Beams, ensure the Hanger's Clamping Bracket is assembled as per image above: The Top Plate of the Clamping Bracket must have "wings" positioned facing downward.

Fig 2. Locating the Clamping Bracket in the 50mm Beam

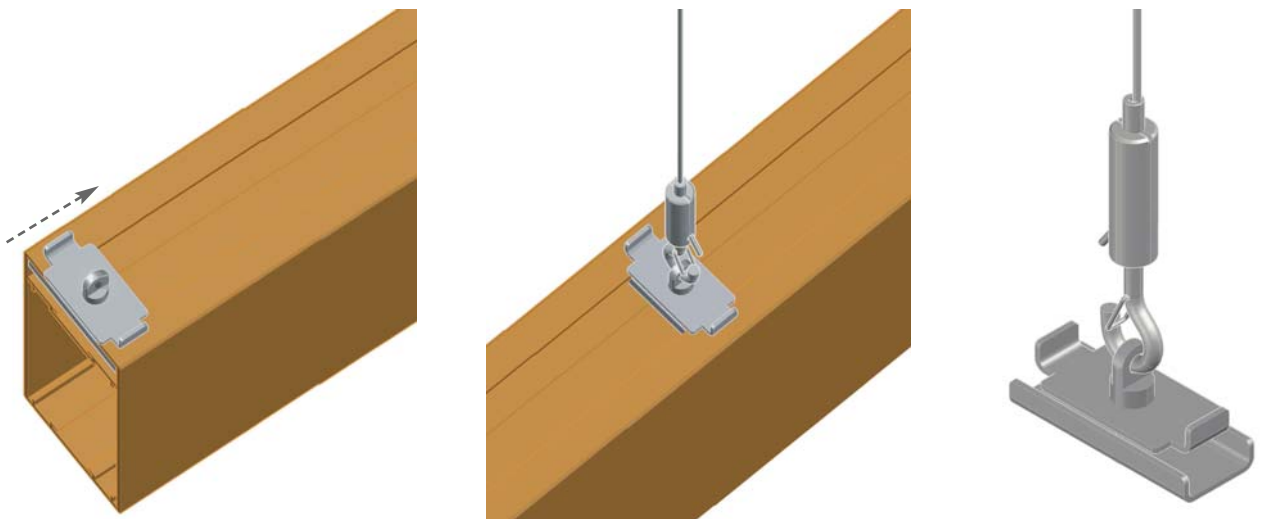

Slide Clamping Bracket from end of Beam

Position Clamping Bracket at 1000mm OC, and attached Gripper Hook

Note: For 50mm wide Beams, ensure the Hanger's Clamping Bracket is assembled as per image above: The Top Plate of the Clamping Bracket must have "wings" positioned facing upward.

2.7 Connecting Beams

Beams are connected at ends with Joiners (item UNI112S), which are inserted into the top and bottom slots of the Beam section and fastened with grub screws. It is recommended that the bottom Joiner is located 1st and fastened on one side only. The top Joiner is then fitted and secured with grub screws, also on one side.

Then the two Beam sections are joined and the top Joiner is screw fastened on the 2nd Beam profile (see Fig. 3).

Where required, End Caps are located on exposed ends of Beam sections. End Caps are simply located by pushing into the Beam section. However due to manufacturing tolerances there may be a requirement to apply construction adhesive to the End Cap to avoid it from falling out (see Fig 3).

2.8 Cutting Options

Beam sections are to be cut to specified length on site, using an aluminium drop saw.

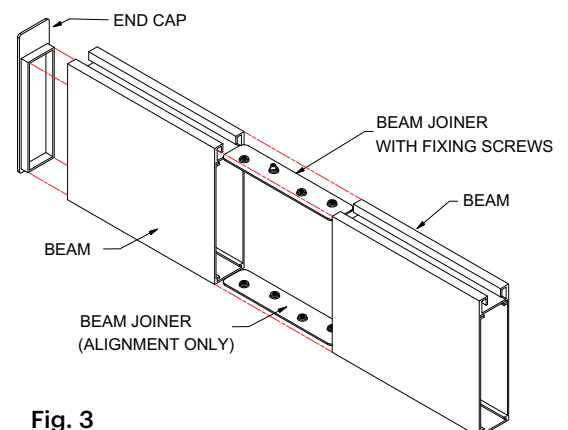

Fig. 3

MetalWorks Modular Beams Installation Guide

2.9 Locating Cross Beams

1. Having installed the Primary Beams as per drawings and specification, cut Cross Beams to length. Insert Hook Over End Caps at both ends of each Cross Beam and screw fix into position as per Fig 4 & 5.

Fig 4. Location of Hook Over End Cap into 25x100mm Cross Beam

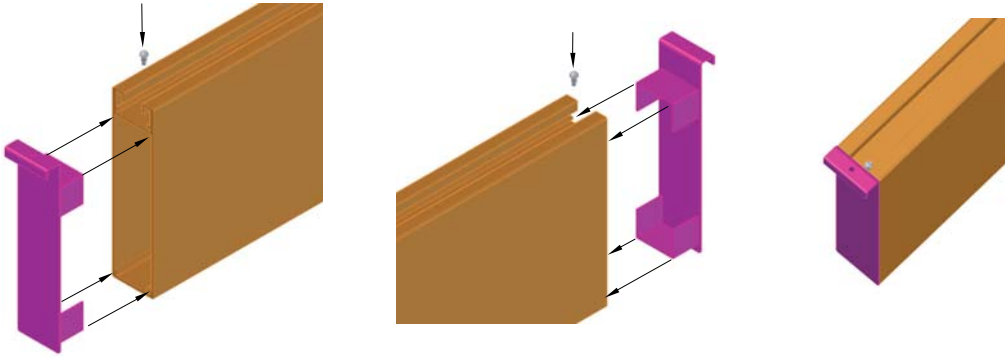
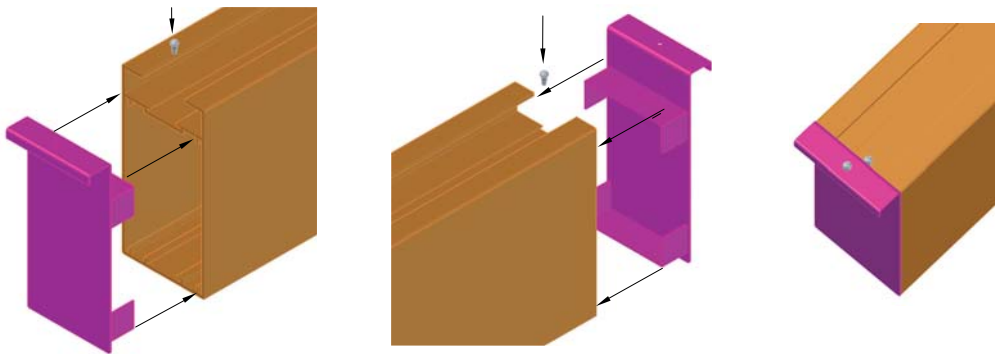

Fig 5. Location of Hook Over End Cap into 50x100mm Cross Beam



Note: Due to manufacturing tolerances it is recommended that construction adhesive be applied to the End Cap locating flanges to ensure it is securely fixed to the Beam end.

2. Locate and position Cross Beams according to drawings and specification. Screw fix accordingly as per Fig 6 & 7.

Fig 6. Fixing 25x100mm Cross Beams

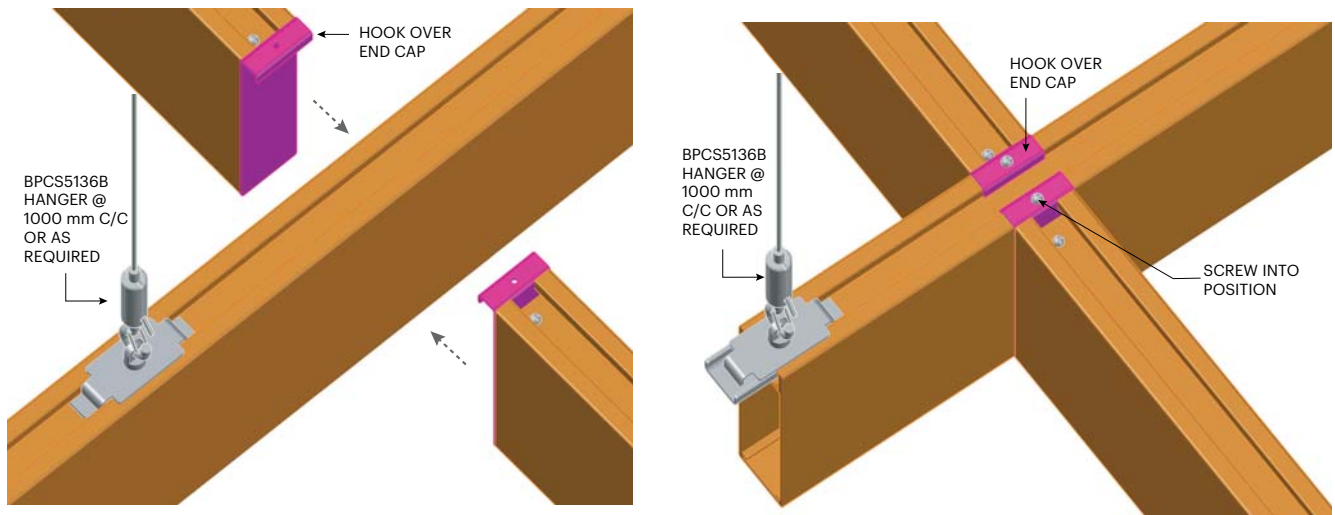

MetalWorks Modular Beams Installation Guide

Fig 7. Fixing 50x100mm Cross Beams

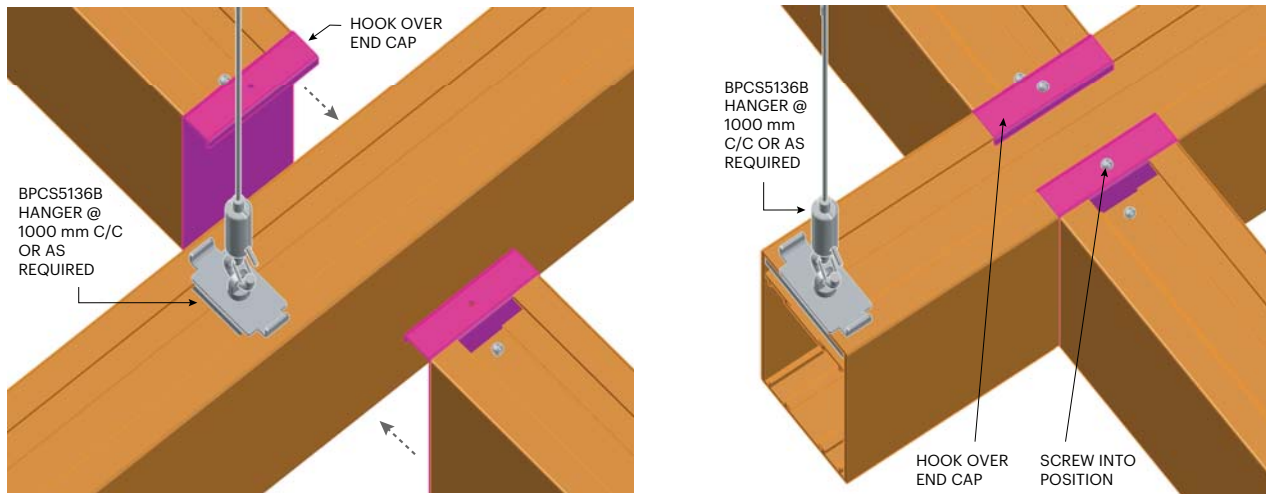

3. BEAM REMOVAL

All Beams are removable without moving up into the plenum.

Procedure: Beams are removed by reversing the Installation procedure illustrated on previous page.

4. BACKLOADING

Unless approved, Armstrong metal ceilings are designed to support only their own weight plus that of light weight insulation. All mechanical services must be independently supported.

5. MAINTENANCE

Ceiling Beams may be cleaned at any time. However, any maintenance work on suspended ceilings should only be carried out after the technical functions of the ceiling installation have been carefully checked. In cases of doubt, the relevant Armstrong sales office should be contacted.

In the case of damage to individual Beams, these can be exchanged within the systems. In such instances, especially after extended periods of use, colour variations may occur when individual tiles are replaced.

Armstrong – paint coatings

Armstrong ceiling Beams are finished with a polyester powdercoat.

Cleaning of Armstrong METALWORKS® ceilings

The frequency of cleaning will depend upon the function and usage of each area and the efficiency of the air conditioning/heating system. This period can only be determined after handover and occupancy. Although the ceiling materials are provided with durable paint finish, abrasive or strong chemical detergent should not be used. A mild detergent diluted in warm water applied with a soft cloth, rinsed and finally wiped off with a chamois leather will maintain the ceiling in good condition. Oily or stubborn stains if not removed by washing can be wiped off with white spirit but care is necessary to avoid affecting the gloss level of the paint finishes.

Contact us

NSW/ACT

Armstrong Ceiling Solutions (Australia) Pty. Ltd.
Unit 4, 1 Basalt Road, Pemulwuy NSW 2145
Telephone (02) 9748 1588

VIC/TAS

Armstrong Ceiling Solutions (Australia) Pty. Ltd.
Unit 1, 88 Henderson Road, Rowville VIC 3178
Telephone (03) 8706 4000

QLD / NT

Armstrong Ceiling Solutions (Australia) Pty. Ltd.
6 Barrinia Street, Slacks Creek QLD 4127
Telephone (07) 3809 5565

SA

Total Building Systems Pty. Ltd.
160 Grand Junction Road, Blair Athol SA 5084
Telephone (08) 7325 7555

WA

Ceiling Manufacturers of Australia Pty. Ltd.
3 Irvine Street, Bayswater WA 6053
Telephone 08) 9271 0777

New Zealand

Forman Building Systems Ltd.
27B Smales Road, East Tamaki, Auckland 2013
Telephone 64-9-276 4000

