

MetalWorks Open Cell

1. GENERAL

1.1. Product Description

MetalWorks Open Cell is a collection of powdercoated aluminium ceiling panels, including a proprietary suspension system. The range consists of 4 Cell sizes, from 75x75, 100x100, 150x150 and 200x200mm, with 2 panel sizes: 600x600 and 1200x600mm (nom). The panels are all 38mm deep and create a more open visual in the ceiling plane. The Suspension System shall be Armstrong PEAKFORM Suprafine 15mm Flat Faced Tee, with Main Bars at 1200mm Centres and Cross Runners at 600mm Centres. (1200x600 module).

Suspension Hangers (Clips) shall be Item SCDGS fitted to Item BPSC300 "Looped wire" at 1200mm centres (refer to illustration below for details).

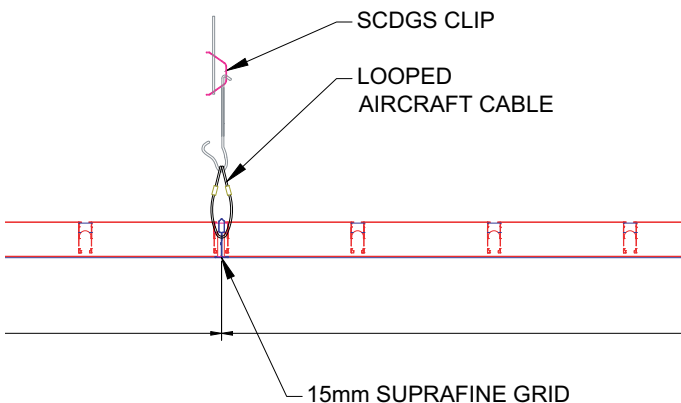

2. INSTALLATION INSTRUCTIONS

Armstrong METALWORKS® ceilings are **INTERIOR FINISHES ONLY** and conditions during the installation should reflect this. Armstrong recommends during installation that relative humidity should not exceed 99%, within a temperature range of 0 to 49 degrees Celsius and with the absence of any "standing water". Conditions following completion should be maintained as such.

Because of the risk of soiling, the installation of ceiling tiles should only take place after the completion of any work generating large amounts of dust. The wearing of clean gloves is recommended for installation work. The ceiling installer is responsible for the satisfactory installation of the

ceiling and adherence to industry best practice and in accordance with AS/NZS2785:2020

Ceiling tiles should only be stored in a dust-free and dry area. It is important to ensure that the tiles are not subjected to any mechanical influences, such as damage caused by the underlying surface. Ceiling tiles delivered on pallets should be stored in their original packaging until they are installed. Where this is not possible, care should be taken to ensure that cartons are stored with the designated side facing upwards. The installation company is responsible for the careful storage of tiles.

The ceiling system is made up of Armstrong METALWORKS Open Cell panels which are supported by the Armstrong Suspension System comprising of PeakForm Suprafine Main & Cross Runners, with Hangers and Wall Angle which runs around the perimeter of the space.

The integrity of the entire suspended ceiling depends on the Suspension Hangers as per adjacent illustration and detail, plus 5mm gal Rod (with some contractors using 2.5mm wire), (Both types meet Australian / New Zealand standard 2785-2020) which are used to support the Main Runners. Bracing is to be applied where required to ensure the Suspension System remains square.

***Note: Specially designed MetalWorks Ceilings for EXTERIOR applications are available upon request. Contact your Armstrong Ceiling Solutions Representative for details and conditions.**

2.1 Cutting Options

Cutting procedures will be similar regardless of panel material or edge configuration. Two different types of equipment are recommended for cutting these metal panels. Each has its own set of advantages and limitations and will be presented in order of preference based on speed.

CAUTION: Cut edges of metal parts can be extremely sharp! Handle metal carefully to avoid injury. Always wear safety glasses and gloves when working with metal.

2.2 Electric Grinder

The use of a grinder with a thin metal cutoff blade will produce an excellent result. This will produce a clean cut, and is quicker than using aviation snips.

Procedure: Mark the cut line on the face of the panel. Cut the panels face up.

2.3 Aviation Snips

Both left cut and right cut aviation snips will be required for cutting operations.

2.4 Infill Panels

Infill panels that suit the open cell size are available, suitable for sprinkler heads and light weight down lights. less than 2 kgs. Refer to the MetalWorks Open Cell Brochure for more details.

2.5 Backloading

Unless approved, Armstrong metal ceilings are designed to support only their own weight. All mechanical services must be independently supported.

3. MAINTENANCE

Ceiling tiles may be cleaned at any time. However, any maintenance work on suspended ceilings should only be carried out after the technical functions of the ceiling installation have been carefully checked. In cases of doubt, the relevant Armstrong sales office should be contacted.

In the case of damage to individual ceiling tiles, these can be exchanged within the systems. In such instances, especially after extended periods of use, colour variations may occur when individual tiles are replaced.

3.1 Armstrong – paint coatings

Armstrong ceiling tiles are finished with a polyester powdercoat.

3.2 Cleaning of Armstrong METALWORKS™ metal ceilings.

The frequency of cleaning will depend upon the function and usage of each area and the efficiency of the air conditioning/heating system. This period can only be determined after handover and occupancy. Although the ceiling materials are provided with durable paint finish, abrasive or strong chemical detergent should not be used. A mild detergent diluted in warm water applied with a soft cloth, rinsed and finally wiped off with a chamois leather will maintain the ceiling in good condition. Oily or stubborn stains if not removed by washing can be wiped off with white spirit but care is necessary to avoid affecting the gloss level of the paint finishes.

MORE INFORMATION

For complete technical information, detail drawings, CAD design assistance, installation information and many other technical services, call your local Armstrong Ceilings representative.

For the latest product selection and specification data, visit armstrongceilings.com.au

Contact us

NSW/ACT

Armstrong Ceiling Solutions (Australia) Pty. Ltd.
Unit 4, 1 Basalt Road, Pemulwuy NSW 2145
Telephone (02) 9748 1588

VIC/TAS

Armstrong Ceiling Solutions (Australia) Pty. Ltd.
Unit 1, 88 Henderson Road, Rowville VIC 3178
Telephone (03) 8706 4000

QLD / NT

Armstrong Ceiling Solutions (Australia) Pty. Ltd.
6 Barrinia Street, Slacks Creek QLD 4127
Telephone (07) 3809 5565

SA

Total Building Systems Pty. Ltd.
160 Grand Junction Road, Blair Athol SA 5084
Telephone (08) 7325 7555

WA

Ceiling Manufacturers of Australia Pty. Ltd.
3 Irvine Street, Bayswater WA 6053
Telephone (08) 9271 0777

New Zealand

Forman Building Systems Ltd.
27B Smales Road, East Tamaki, Auckland 2013
Telephone 64-9-276 4000

